

NTR-5

26-9-20

NO-257

A1

CE' 7 200
2

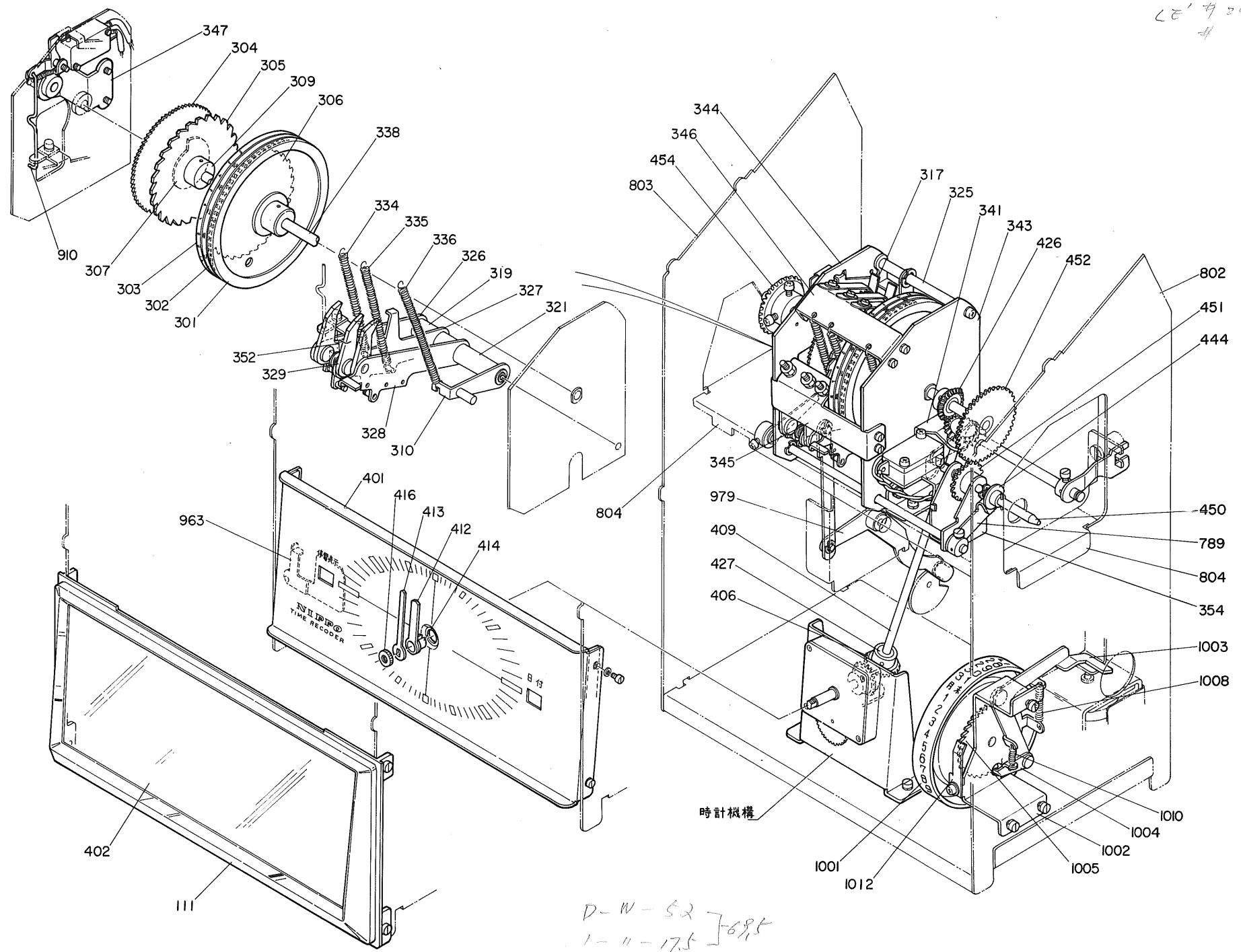

D-W-52
1-11-17.5]-68.5